

**KORDSA**

THE REINFORCER

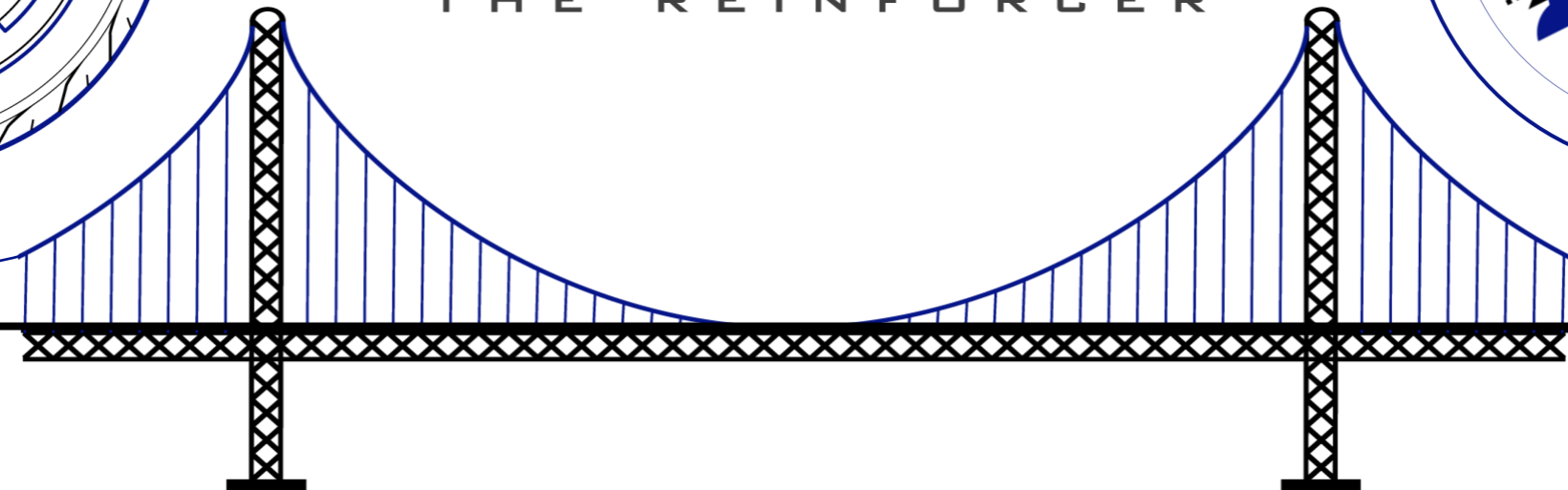
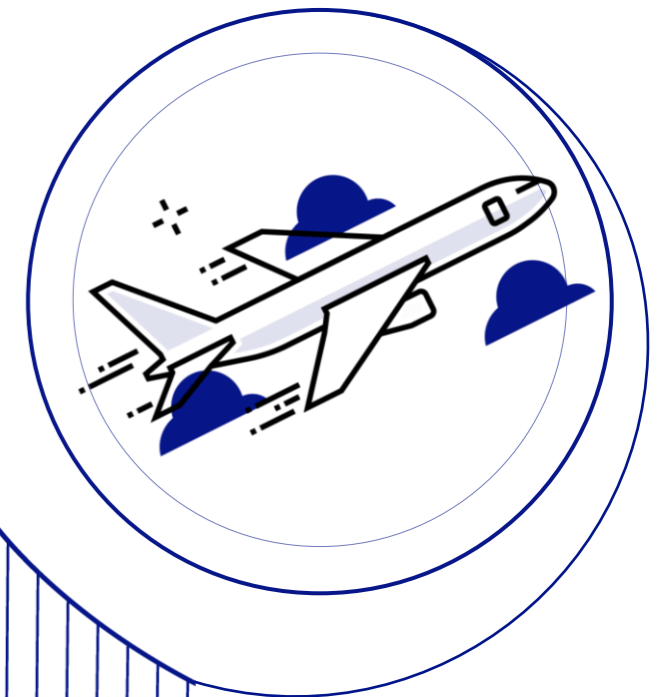

## 1H 2019 – Earnings Release

August 6, 2019

# Disclaimer

*The information and opinions contained in this document have been compiled by KORDSA Teknik Tekstil Anonim Şirketi (the "Company") from sources believed to be reliable and in good faith, but no representation or warranty, expressed or implied, is made as to their accuracy, completeness or correctness. No undue reliance may be placed for any purposes whatsoever on the information contained in this presentation or on its completeness, accuracy or fairness. This document may contain forward-looking statements by using such words as "may", "will", "expect", "believe", "plan" and other similar terminology that reflect the Company management's current views, expectations, assumptions and forecasts with respect to certain future events. As the actual performance of the companies may be affected by risks and uncertainties, all opinions, information and estimates contained in this document constitute the Company's current judgment and are subject to change, update, amend, supplement or otherwise alter without notice. Although it is believed that the information and analysis are correct and expectations reflected in this document are reasonable, they may be affected by a variety of variables and changes in underlying assumptions that could cause actual results to differ materially.*

*The Company does not undertake any obligation, and disclaims any duty to update or revise any forward looking statements, whether as a result of new information or future events. Neither this document nor the information contained within can construe any investment advice, invitation or an offer to buy or sell the Company and/or Its group companies' shares. The Company cannot guarantee that the securities described in this document constitute a suitable investment for all investors and nothing shall be taken as an inducement to any person to invest in or otherwise deal with any shares of the Company and its group companies. The information contained in this document is published for the assistance of recipients, but is not to be relied upon as authoritative or taken in substitution for the exercise of judgment by any recipient. You must not distribute the information in this document to, or cause it to be used by, any person or entity in a place where its distribution or use would be unlawful. Neither the Company, its board of directors, directors, managers, nor any of Its employees shall have any liability whatsoever for any direct or consequential loss arising from any use of this document or its contents.*

# Agenda

1

Global Footprint

2

1H 2019 Highlight

3

Market Dynamics

4

RM Price Drivers

5

Segment Reporting

6

New Products

7

Update on 1H 2019 Results

8

Dividend Distribution

9

Operating Bridge

10

Guidance



# Global Footprint

**4** continents  
**12** facilities\*

**~4,500**  
employees

**2** R&D  
Centers

**852** patent application  
**184** patents  
**186** inventions

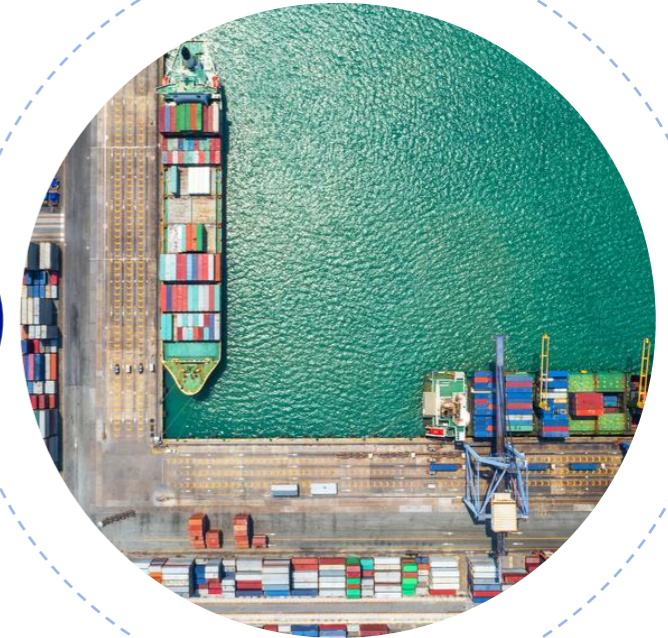

# WE REINFORCE LIFE

\* Axiom Materials Acquisition LLC included

# 1H 2019 Highlights

	TL Financials (MTL)			USD Financials (MUSD)		
	1H 2018	1H 2019	Δ	1H 2018	1H 2019	Δ
Sales	1,538	2,586	68.1%	377	461	22.4%
EBITDA*	263	407	54.9%	64	73	12.8%
EBITDA* Margin (%)	17.1%	15.8%	- 130 bp	17.1%	15.8%	- 130 bp

Our company guidance for financial year 2019 is as follows:

- Revenue : 30%-40% TL basis; 10%-15% USD basis
- EBITDA : 30%-40% TL basis; 10%-15% USD basis
- Composite business segment revenue : 105-115 M\$



## Tire cord fabrics ("TCF")

- Strong market position,
- Decrease on growth rates in both automotive sector and tire reinforcement market.
- Sustainable growth rate on profitable products,
- Finalized polyester yarn line investment in the second quarter in Izmit Plant
- Launched CoKoon

## Composite

- Started and finalized the acquisition process of Axiom Materials which provide advanced composite materials to the aerospace industry as well as the next generation transportation vehicles,
- 280 M\$ acquisition expenditures in the last two years can help us to create additional 150M\$ annual sales in this segment
- Potential M&A targets are always under consideration,

## Construction

- Kratos Macro & Micro Synthetic Fibers are approved and applied in over 50 significant superstructure, industrial and infrastructure reference projects.

EBITDA\* = Gross Profit – OPEX + Depreciation/Amortization

# Axiom Materials Acquisition LLC



## General

- Axiom is a leading developer and manufacturer of proprietary advanced composite materials
- Sole supplier to over 100 customers, with over 200 aerospace product qualifications and 50 industrial product qualifications
- 100,000+ SF in four manufacturing buildings in Santa Ana, CA
- 110 employees, 40% Technical

## Products

- Prepregs, woven and unidirectional and other advanced composite materials,
- Supplies advanced composite materials for engine components, aircraft interiors, structural components, and cargo liners
- Supports a variety of alternative energy / storage and construction applications
- Supports a range of high-performance auto customers

## Financials

- Axiom has grown nearly %15-20 annually over the historical period,
- 43.4 M\$ annual sales in 2018
- EBITDA margins in composite prepreg ranging between 15-25% and close to the highest EBITDA margin in the composite prepreg market,
- Kordsa's 2019 guidance will be updated in the following weeks to cover Axiom's effect.



# Market Dynamics

## Global Automotive Market

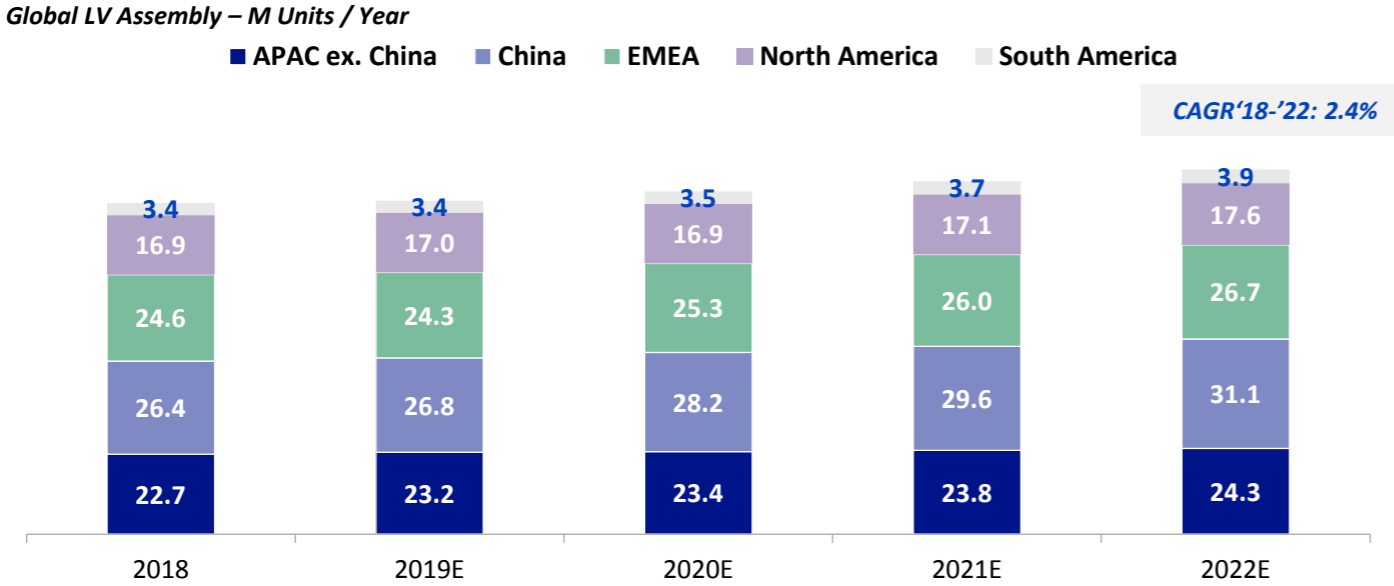

### 2019 Expectations

- **AP Exc. China:** +2.4% Highest growing region because of slowing other regions
- **China:** +1.6% Effected by tariff wars
- **EMEA:** -1.3%
- **NA:** 0.3% Crossover segment demand is strong
- **SA:** -2.1% Expected market recovery was not utilized in 2018 as a result of economic developments, slow trend to continue in 2019

## Global Tire Market

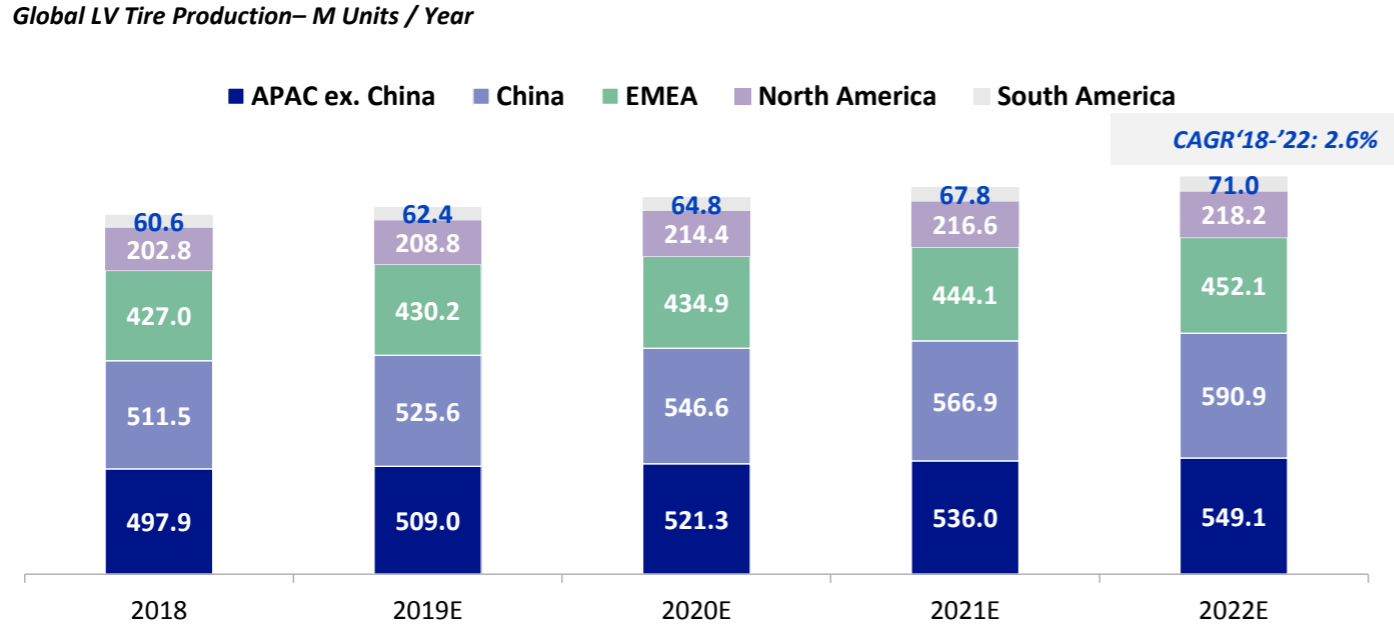

### 2019 Expectations

- **OE:** Sales were 6.6% lower during the first four months of 2019, with declines in China, US and no growth for Europe,
- **Replacement:** Decrease in miles driven especially in China, replacement cycle of tires are moving from 4 years to 5 years. Also tire lives are improving.

# Market Dynamics

## Tire Reinforcement Market (NY6.6)

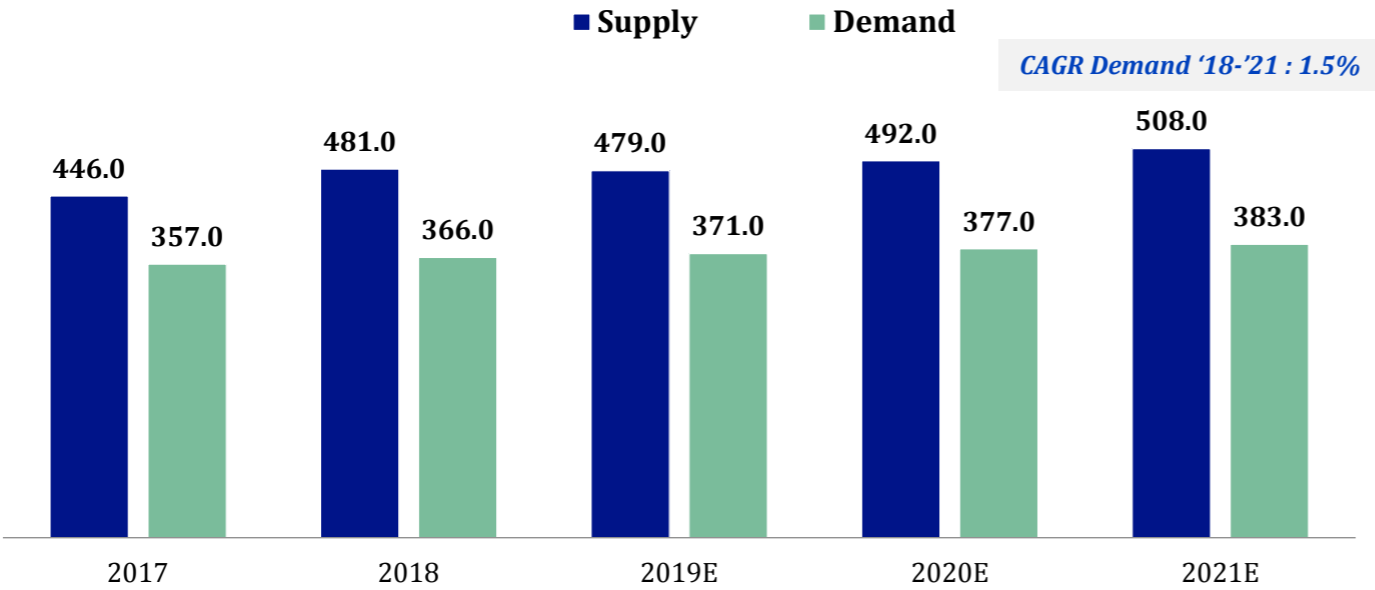

Source: Company Estimates

## Tire Reinforcement Market (PET)

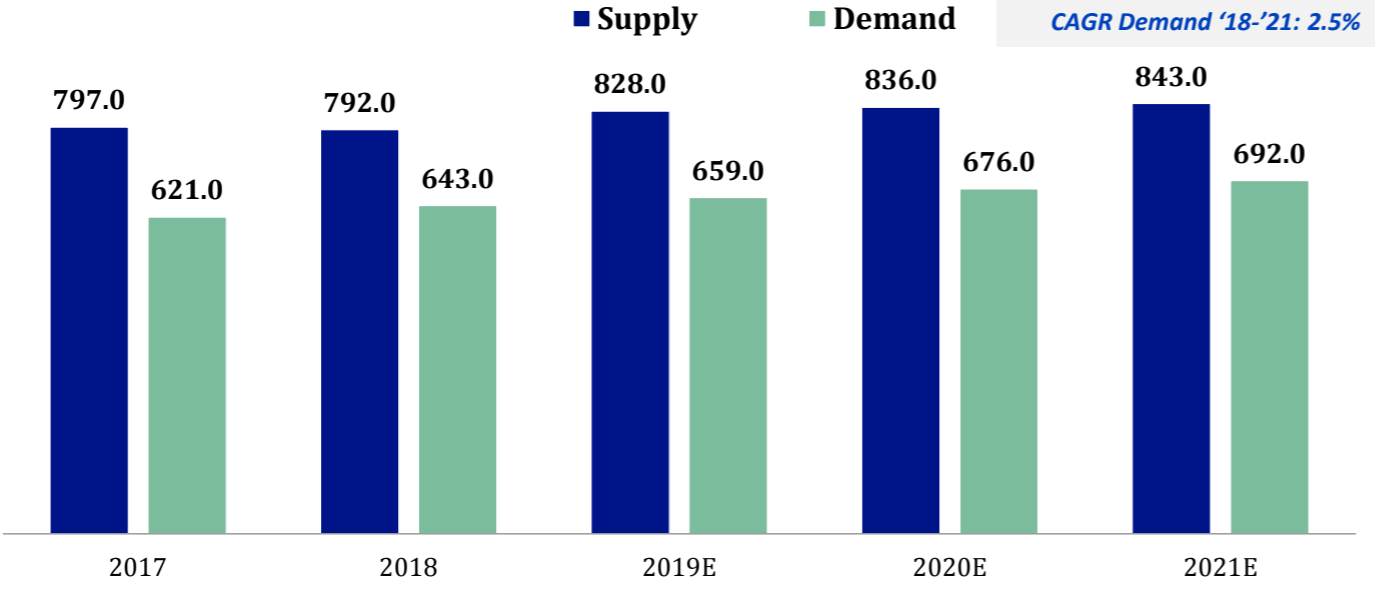

Source: Company Estimates

**Nylon 6.6**

- Utilization rates lower compared to previous years
- Engineering plastics is affected by Automotive markets' slow down
- Switching to NY6
- Market slow-down is reflected to market estimations. NY66 demand increase updated as 1.5%

**PET HMLS**

- Consolidation by Indorama (acquiring PF Kaiping, Glanzstoff, Durafiber)
- Increasing PET usage in Tire
- Market slow-down is reflected to market estimations. PET demand increase updated as 2.5%



# RM Price Drivers

## NY Raw Material Trend (Indexed)

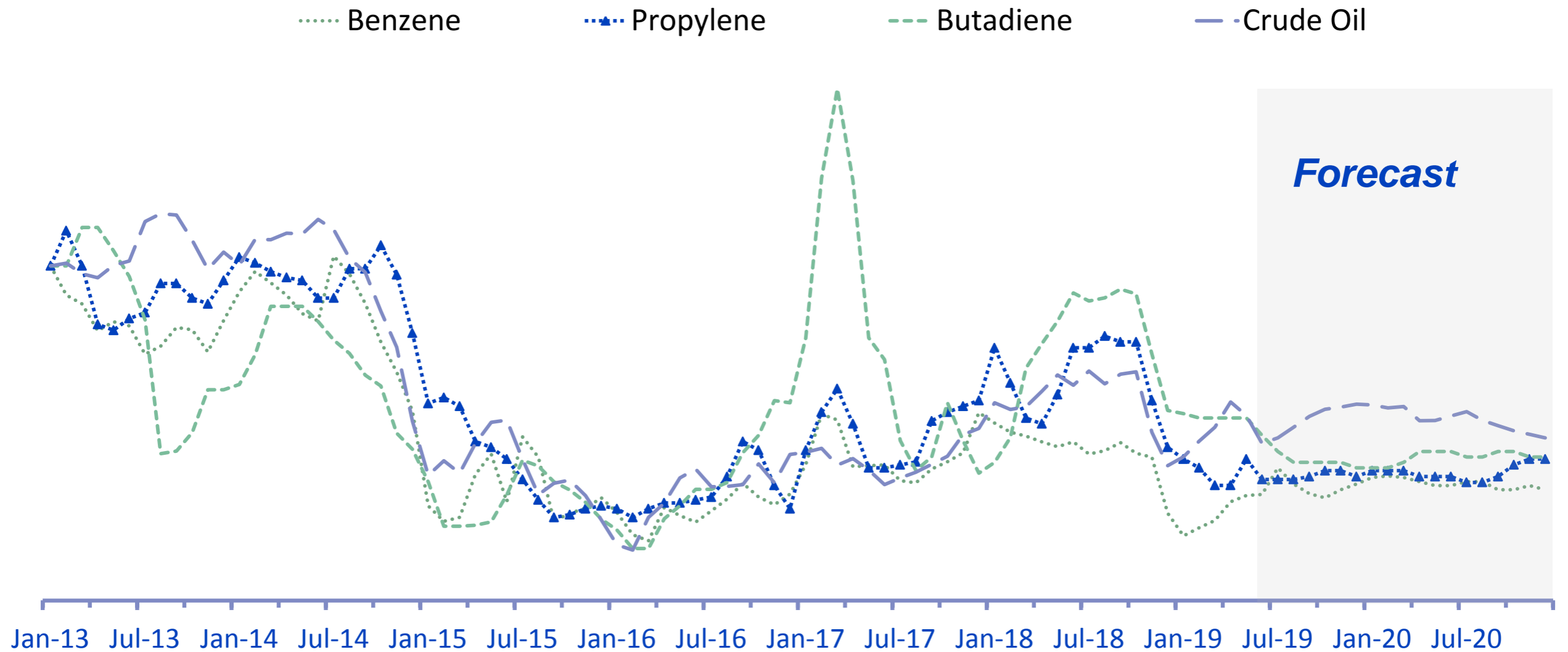

# RM Price Drivers

## PET Feedstock Asia

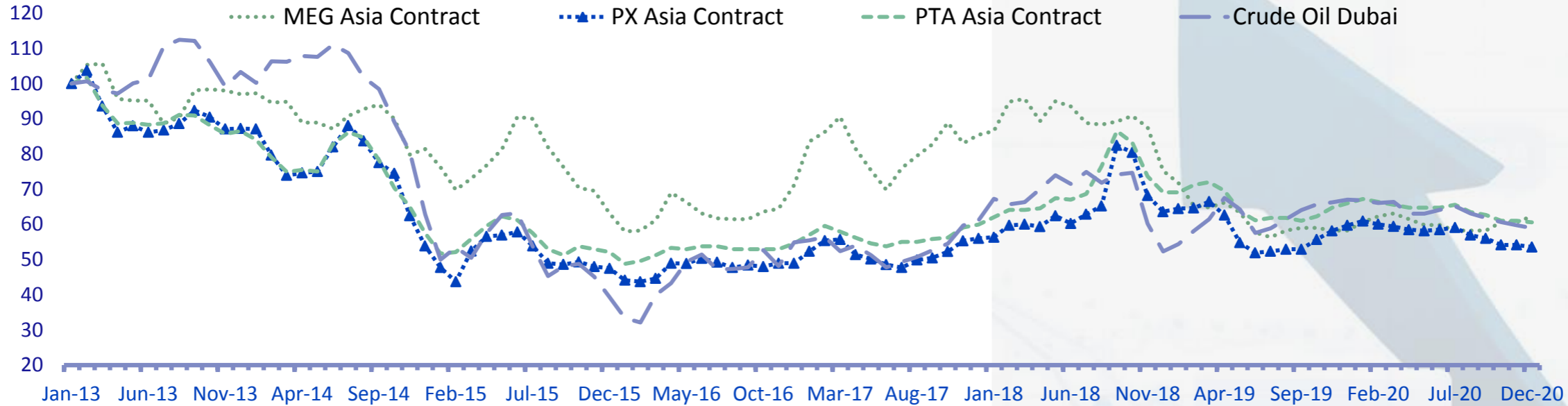

Source : IHS Markit

## PET Feedstock West Europe

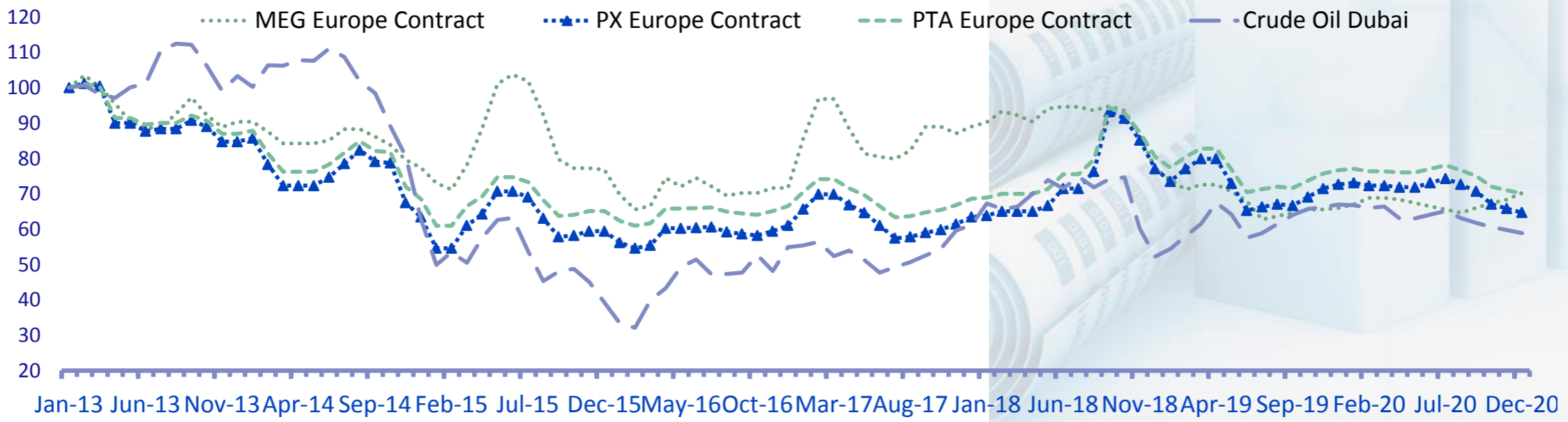

# Capitalize on Global Footprint and Entrenched Supplier Status with All Key Tire Manufacturers - Segmental Progress

■ Global Players ■ Regional Players ■ Emerging Players ■ Others

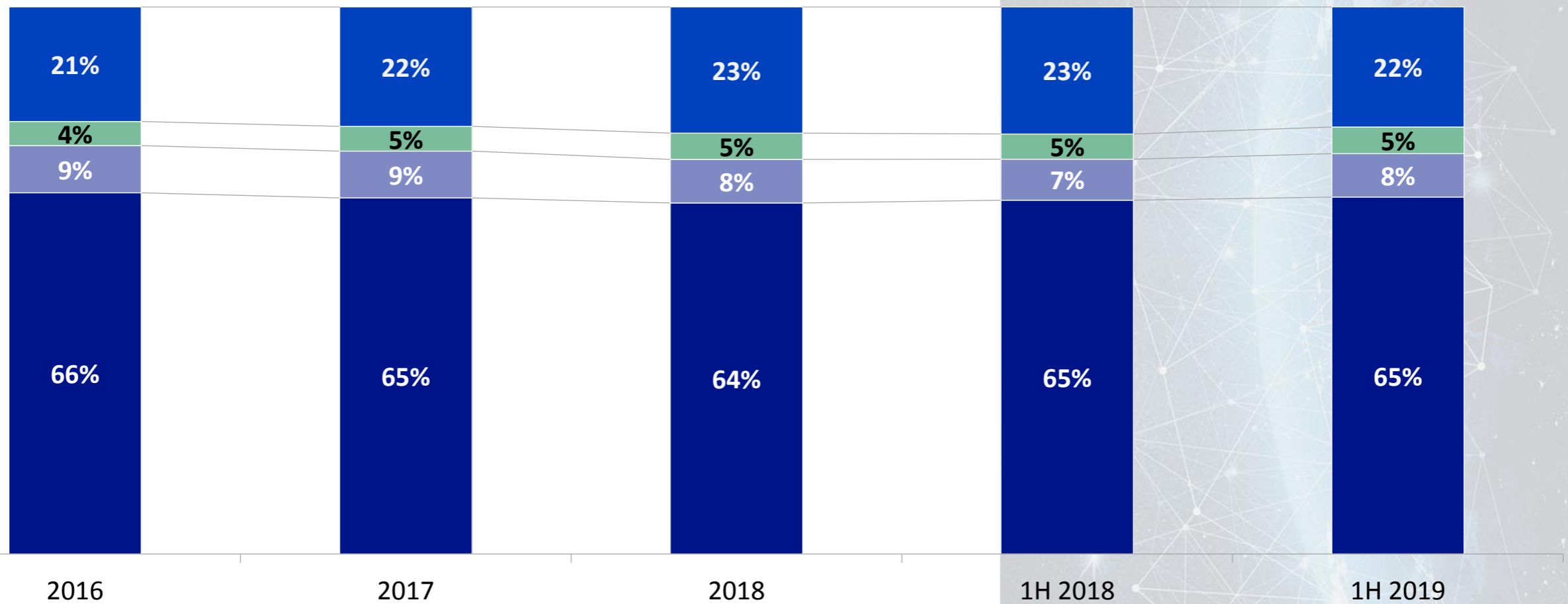

# Global Footprint

## By Revenue

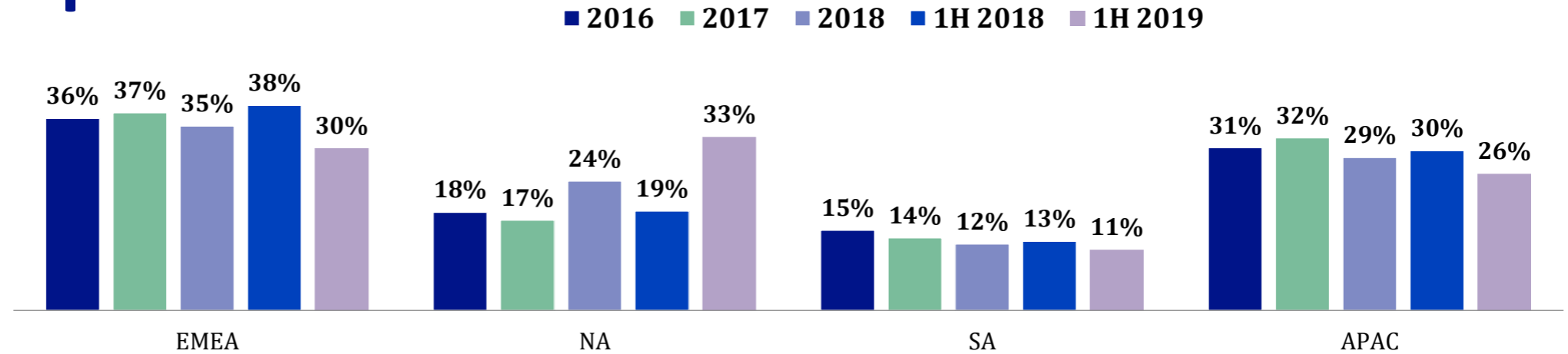

Regional footprint versus key competitors



Kordsa market position

- #1 NY TCF producer
- #1 PET TCF producer

- #1 NY TCF producer in the US
- 3 composite manufacturing plants

- The only PET yarn, TCF and SEC producer in LATAM

- #2 NY TCF producer
- #2 PET TCF producer

# 1H 2019 Revenue Split Progress by Products

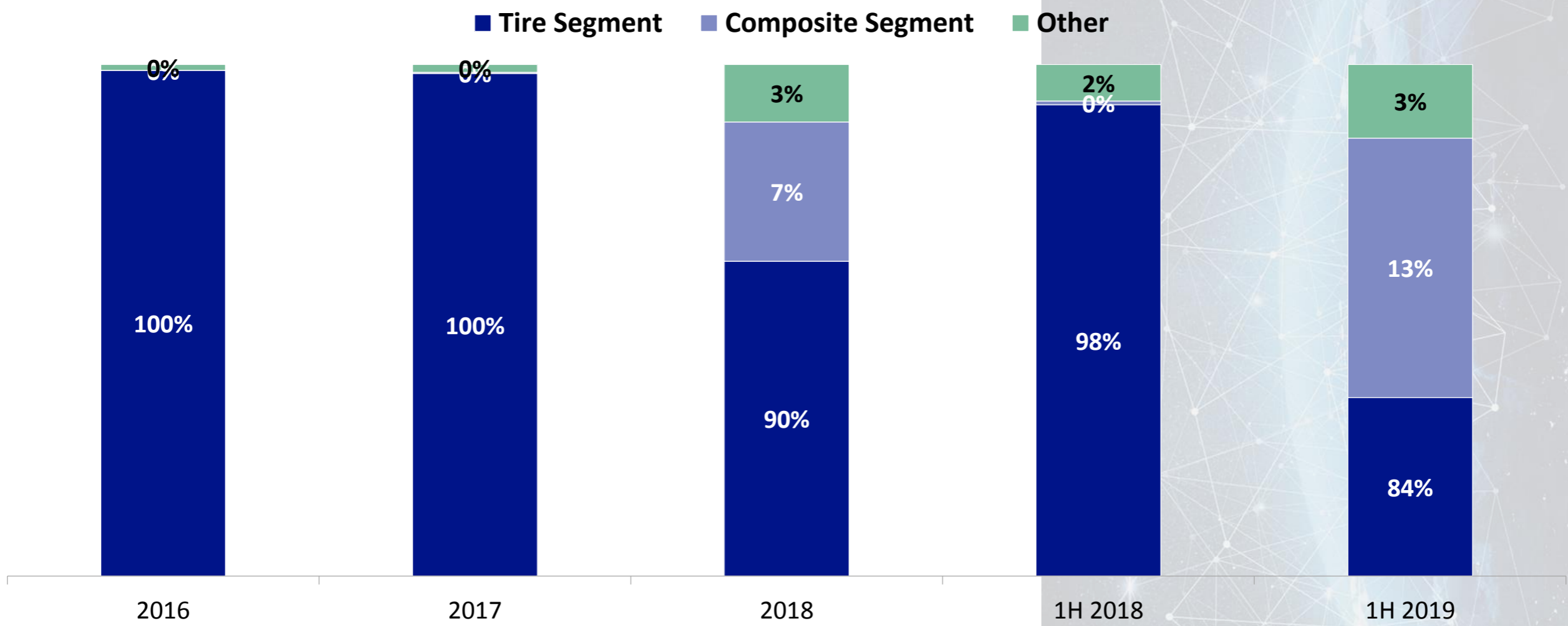

# Technology Leadership at The Cutting Edge of Reinforcement

## Strong focus on R&D

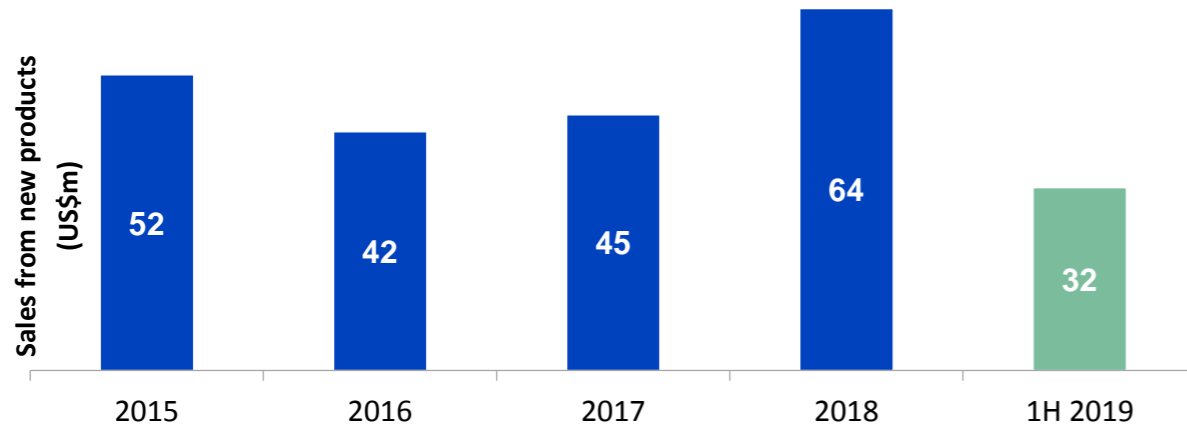

## Selected collaborations(a)



(a) includes both, universities as well as individual academics from the names institutions

## Cutting edge new products



✓ Rolling resistance improvements through higher modulus for high performance tires



✓ Protection layer for truck & bus tires; reduces tire weight

**T802**

✓ 7% higher tenacity and better fatigue performance for aircraft tires (bias)

**4G PET**

✓ 10% higher dimensional stability for better tire performance (improved labeling)

## Leadership in Innovation and Technology”



- Kordsa puts into operation the USD 18 million (100 million TL) worth additional polyester yarn line at Izmit Plant.



- Kordsa is the main sponsor of the International Conference of the Polymer Processing Society, which is one of the most important gatherings in the industry



- 34 companies applied for a sample of CoKoon technology, the environmentally friendly formula – co-jointly developed by Kordsa and Continental – that will replace the 80-year old formula

# Update on 1H 2019 Results

## Key Financials

	TL Financials (MTL)			USD Financials (MUSD)		
	1H 2018	1H 2019	Δ	1H 2018	1H 2019	Δ
Sales	1,538	2,586	68.1%	377	461	22.4%
Gross Profit	328	526	60.3%	80	94	16.7%
Gross Margin (%)	21.3%	20.3%	-1 pts'	21.3%	20.3%	-1 pts'
OPEX (%)	8.2%	8.1%	0 pts'	8.2%	8.1%	0 pts'
Operating Profit	244	361	48.3%	60	64	8.0%
Operating Profit Margin (%)	15.8%	14.0%	-2 pts'	15.8%	14.0%	-2 pts'
EBITDA*	263	407	54.9%	64	73	12.8%
EBITDA* Margin (%)	17.1%	15.8%	-1 pts'	17.1%	15.8%	-1 pts'
Net Income	155	219	40.9%	38	39	2.6%
Effective Tax Rate (%)	18.1%	21.6%	4 pts'	18.1%	21.6%	4 pts'
Net Income (%)	10.1%	8.5%	-2 pts'	10.1%	8.5%	-2 pts'
EPS (TL/1,000 shares)	6.98	9.83	40.8%	1.71	1.75	2.5%

\* EBITDA Calculation: Gross Margin-OPEX+Dept & Amort

**Kordsa continues to perform well based on its value strategy**

# Update on 1H 2019 Results

## Key Balance Sheet Items

	TL Financials (MTL)			USD Financials (MUSD)		
	YE 2018	1H 2019	Δ	YE 2018	1H 2019	Δ
Cash and Cash Equivalents	131	524	393	25	91	66
Account Receivables	830	976	146	158	170	12
Inventories	1,048	1,343	296	199	233	34
Other Current Assets	140	171	30	27	30	3
PPE & Intangibles	2,233	2,380	147	424	413	-11
Investment Property	115	126	11	22	22	0
Goodwill	172	245	73	33	43	10
Other Non-Current Assets	162	155	-7	31	27	-4
Account Payables	572	801	229	109	139	30
Total Debt	1,519	1,965	446	289	342	53
Short Term Debt	994	1,433	438	189	249	60
Long Term Debt	525	533	8	100	93	-7
Other Liabilities	400	511	111	76	89	13
Net Debt (Cash&Cash Equ. Excluded)	1,388	1,442	53	264	251	-13
WCAP Turnover	2.95	3.55		2.95	3.55	
Net Debt / EBITDA	2.23	1.88		2.36	1.82	



# Update on 1H 2019 Results

Free Cash Flow			
(in TL million, unless otherwise stated)	1H 2018	1H 2019	Δ
<b>Cash Flows From Operating Activities</b>	<b>45</b>	<b>320</b>	<b>275</b>
Net Income	155	219	64
Depreciation & Amortization	62	92	31
Change in Working Capital	-362	-259	103
Other Adjustments	190	267	78
<b>Cash Flows From Investing Activities</b>	<b>-105</b>	<b>-71</b>	<b>34</b>
Maintenance CAPEX	-105	-71	34
M&A Investments	0	0	0
<b>Free Cash Flow*</b>	<b>-60</b>	<b>249</b>	<b>309</b>

\* FCF:  $EBIT(1-Tax\ Rate) + Depreciation\ \&\ Amortization - Change\ in\ Net\ Working\ Capital - Capital\ Expenditure$ . It can also be calculated by taking operating cash flow and subtracting capital expenditures. - FCF (operational cash flow- capex)

# Dividend Distribution (MTL)

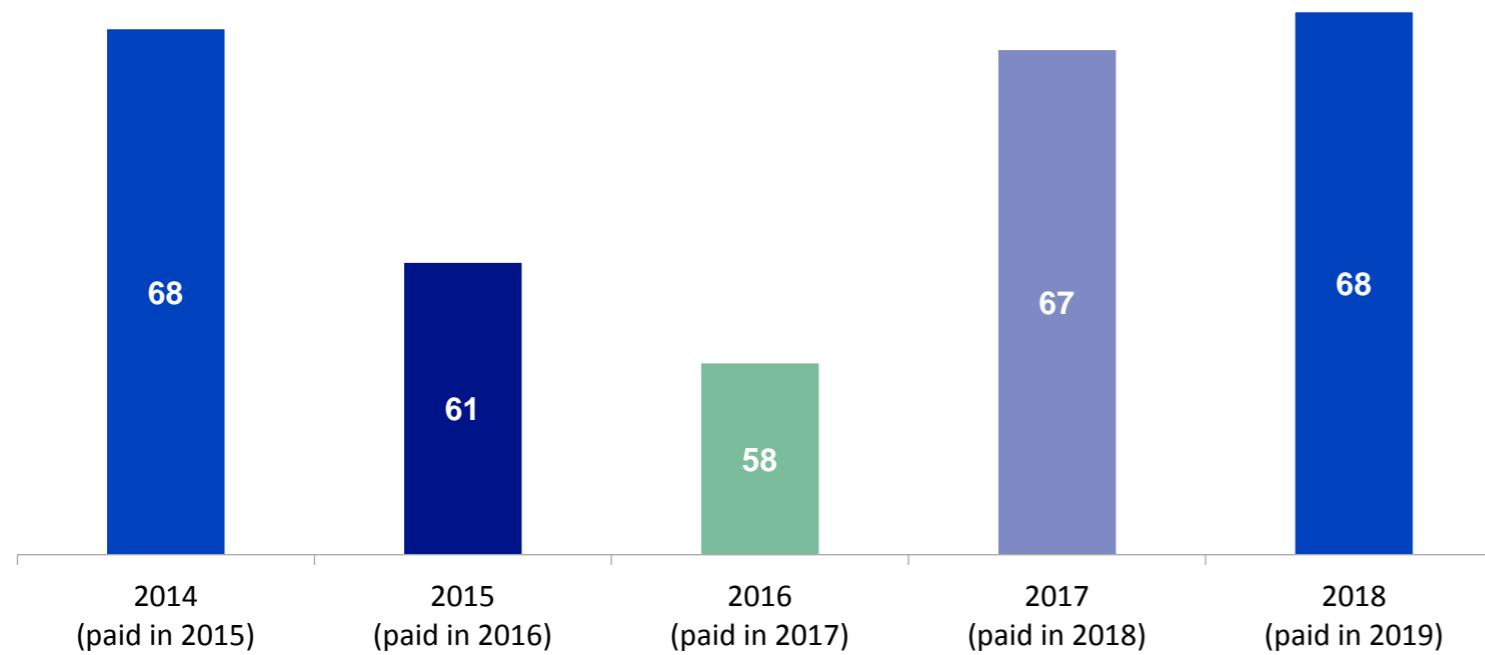

Distribution of all the distributable profits

- which is lower of Kordsa Turkey solo tax books (VUK) or Kordsa consolidated TFRS (IFRS) net income,
- in the form of cash and/or bonus shares subject to General Assembly approval.

The distribution decision is agreed taking into consideration the sizeable fixed asset purchases, acquisitions, covenants of current liabilities and the Company's mid and long term strategies, national and global economic conditions.

Kordsa does not apply payment of advance dividends

# Operating Profit Bridge - MTL

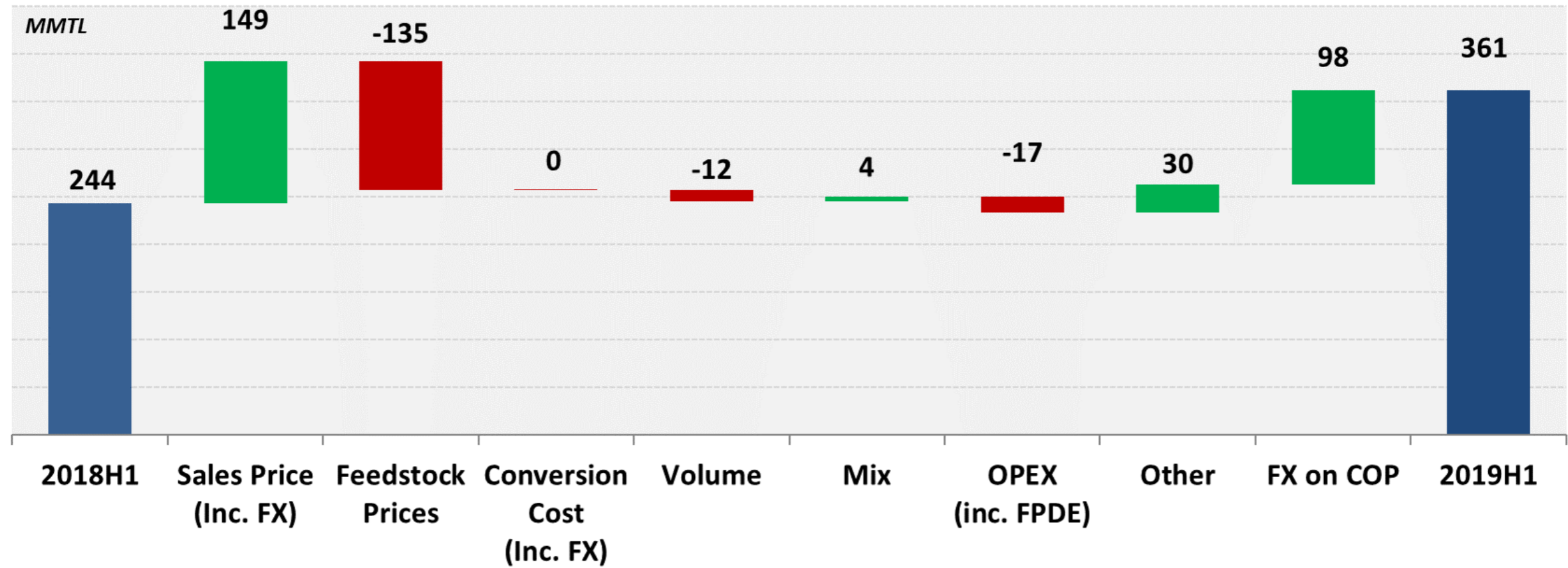

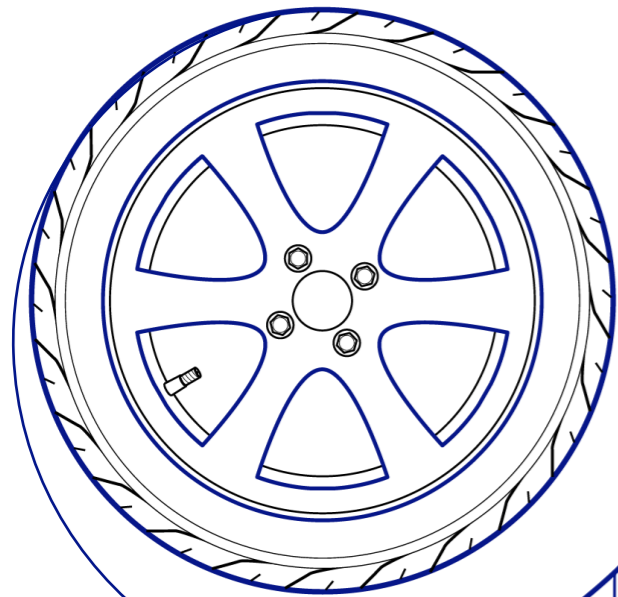

**KORDSA**

THE REINFORCER

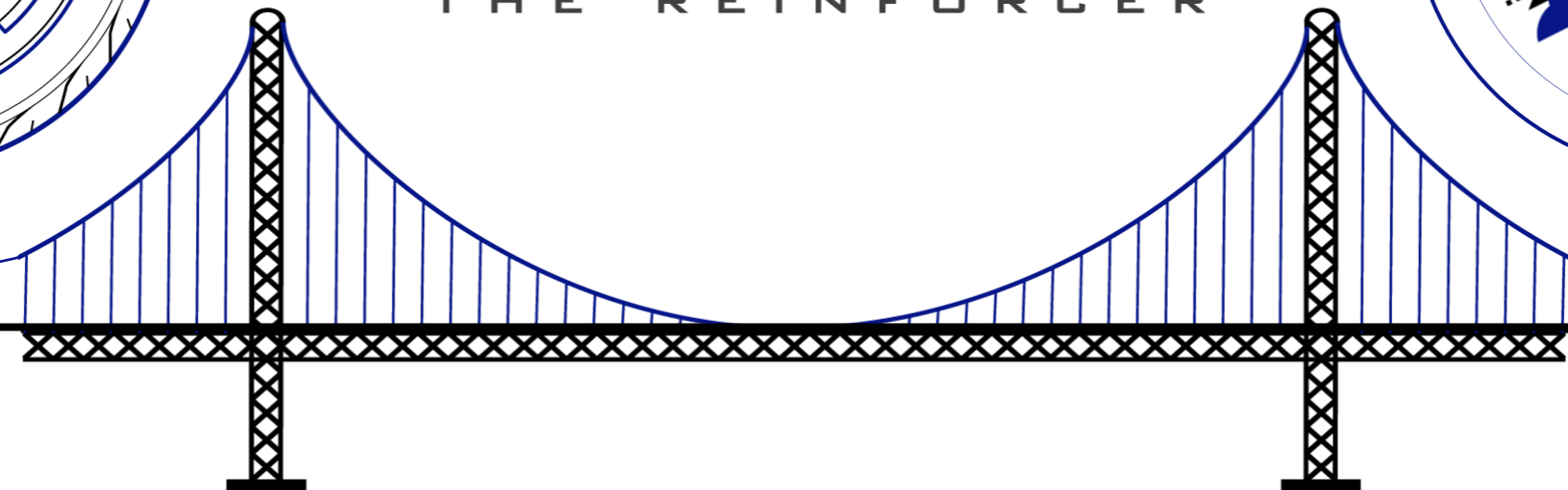

# Appendix

# 2018 – 2019/1H Financial Trend (MTL)

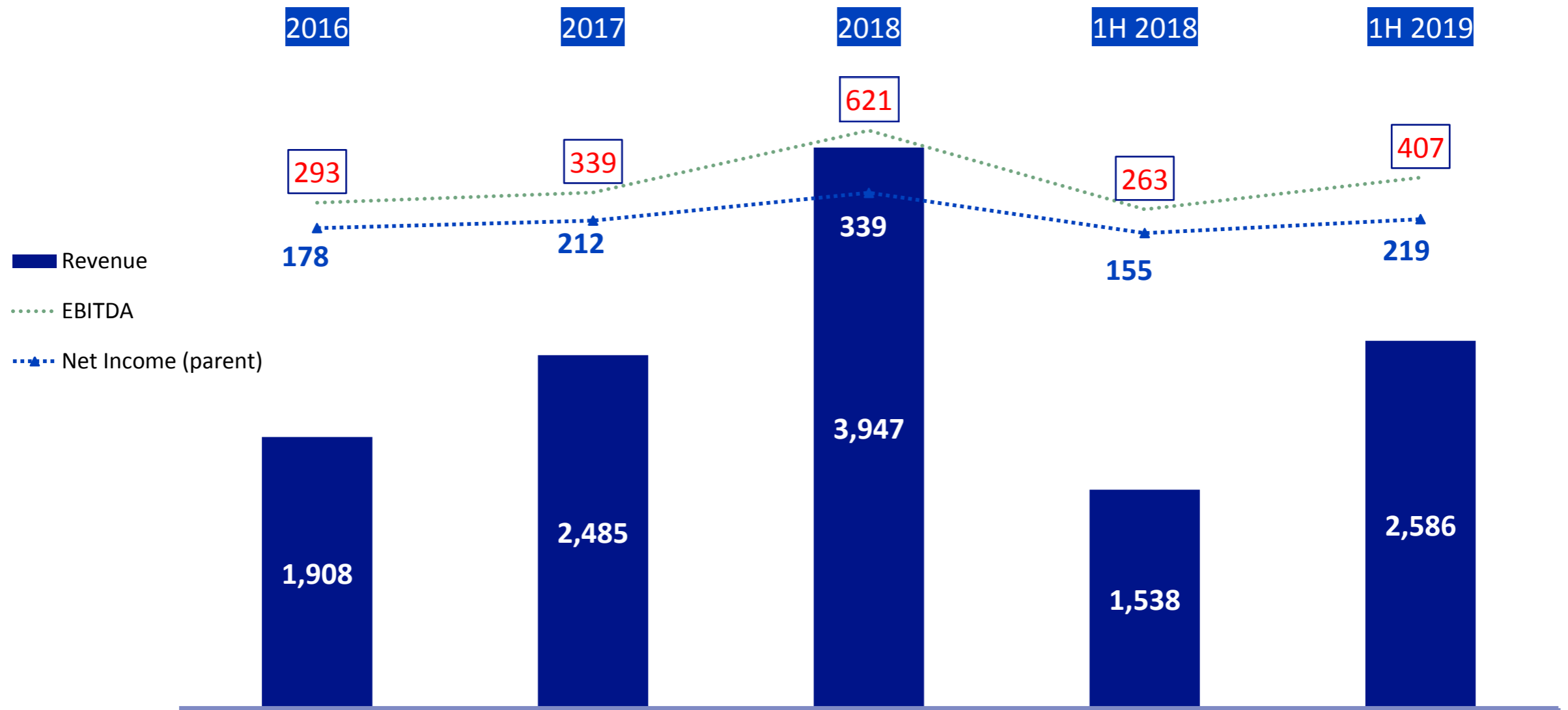

# 1H 2019 Highlights (FX Rates)

